

Ball Float Steam Trap

UNA 45 MAX

UNA 46 MAX

UNA 46A MAX

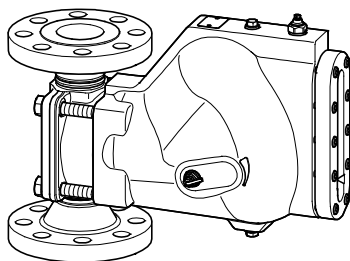
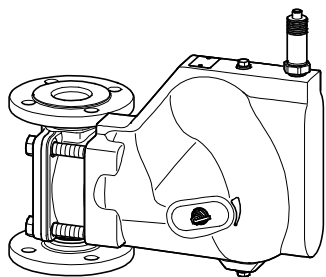
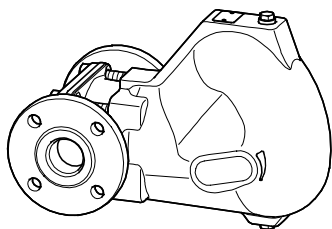

Contents

Foreword	3
Availability.....	3
Formatting features in the document	3
Safety.....	3
Use for the intended purpose	3
Basic safety notes	4
Information on property damage or malfunctions	4
Qualification of personnel.....	4
Protective gear	5
Typographic features of warning notes.....	5
Formatting features for warnings of property damage	5
Description	6
Scope of supply and equipment specification	6
Task and function.....	10
Storing and transporting the equipment.....	11
Storing the equipment	11
Transporting the equipment	11
Mounting and connecting the equipment	12
Preparing installation	12
Orientation of the equipment.....	13
Connecting the equipment	14
Operation	17
After operation	17
Removing external dirt deposits.....	18
Maintaining the equipment.....	19
Servicing the equipment and installing spare parts	24
Troubleshooting	32
Retighten the stuffing-box packing.....	34
Putting the equipment out of operation	35
Removing harmful substances.....	35
Removing the equipment	35
Re-using equipment after storage.....	36
Disposing of the equipment.....	37
Technical data.....	38
Dimensions and weights	38
Pressure & temperature ratings.....	46
Manufacturer's declaration	51

Foreword

This installation & operating manual will help you use the following types of equipment safely and efficiently for their intended purpose.

- ▶ UNA 45 MAX
- ▶ UNA 46 MAX
- ▶ UNA 46A MAX

These steam traps will be called equipment in this document.

This installation & operating manual is intended for anyone commissioning, using, operating, servicing, cleaning or disposing of this equipment and, in particular, for professional after-sales service technicians, qualified personnel and authorised and trained staff.

All of these persons must read and understand the content of this installation & operating manual.

Following the instructions given in this installation & operating manual helps avoiding danger and increases the reliability and service life of the equipment. Please note that in addition to the instructions given in this installation & operating manual you must also observe all locally applicable rules and regulations concerning the prevention of accidents as well as approved safety guidelines for good professional practice.

Availability

Keep this installation & operating manual together with the plant documentation for future reference.

Make sure that this installation & operating manual is available to the operator.

The installation & operating manual is part of the equipment. Please hand over this installation & operating manual when selling the equipment or passing it on.

Formatting features in the document

Certain text elements of this installation & operating manual feature a specific typographic design. You can easily distinguish the following text elements:

Standard text

Cross-reference

- ▶ Listing
 - ▶ Sub-items in listings
- Steps for action.



Here you will find additional useful information and tips serving to assist you in using the equipment to its fullest potential.

Safety

Use for the intended purpose

The following ball float steam traps are designed to discharge condensate from steam systems:

- ▶ UNA 45 MAX
- ▶ UNA 46 MAX
- ▶ UNA 46A MAX

Equipment type UNA 45 MAX can also be used for removing condensate from compressed air systems.

Equipment type UNA 46 MAX and UNA 46A MAX can also be used for removing condensate from gases or gas mixtures.

The equipment must only be used within the allowable pressure and temperature limits and only if the chemical and corrosive influences on the equipment are taken into account.

Do not expose the membrane regulator capsule of the DUPLEX control unit to superheat conditions above 5 K.

Correct use includes compliance with the instructions given in this installation & operating manual, in particular obedience to all safety instructions.

Any other use of the equipment is considered to be improper.

Note that the equipment is also used incorrectly if the materials of the equipment are not suitable for the fluid.

Basic safety notes

Risk of severe injuries

- ▶ The equipment is under pressure during operation and may be hot. Before carrying out any work on the equipment make sure that the following requirements are met:
 - ▶ The pipes must be depressurized (0 bar).
 - ▶ The fluid must be completely removed from the pipes and the equipment.
 - ▶ During work on the equipment the installation must be switched off and protected against unauthorised or unintended activation.
 - ▶ The pipes and the equipment must have cooled down to room temperature (approx. 20 °C).
- ▶ If the equipment is used in contaminated areas there is a risk of severe injuries or death caused by harmful substances in or on the equipment. Before working on the equipment make sure that it is completely decontaminated. Always wear the protective clothing prescribed for contaminated areas when working on the equipment.
- ▶ The equipment must only be used with fluids that do not attack the material and the gaskets and sealings of the equipment. Otherwise leaks may occur and hot or toxic fluid could escape.
- ▶ The equipment and its component parts must only be mounted or removed by qualified personnel. A qualified person must be acquainted with and experienced in the following:
 - ▶ Making pipe connections.
 - ▶ Selecting suitable lifting gear and understanding the rules for its safe use.
 - ▶ Working with dangerous (contaminated, hot or pressurized) fluids.
- ▶ If the admissible temperature and pressure limits are exceeded the equipment may be destroyed and hot or pressurized fluid may escape. Make sure that the equipment is only operated within the admissible service range and limits.
For more information on limits and pressure &

temperature ratings see name plate and the section "*Technical Data*".

Risk of minor injuries

- ▶ Sharp edges on internals present the danger of cuts to hands. Always wear industrial gloves when servicing the equipment.
- ▶ If the support of the equipment during installation is insufficient the equipment might fall down, thereby causing bruises or injuries. Make sure the equipment is safely held in place during installation and cannot fall down. Wear protective safety footwear.

Information on property damage or malfunctions

- ▶ Malfunctions will occur if the equipment is installed in a wrong position or with the flow arrow pointing in the opposite direction of the fluid flow. This may result in damage to the equipment or the installation. Make sure that the flow arrow on the equipment body matches the indicated direction of the fluid flow in the pipe.
- ▶ If the material is unsuitable for the fluid, increased wear may occur and fluid may escape. Make sure that the material is suitable for the fluid used in your installation.

Qualification of personnel

A qualified person must be acquainted with and experienced in the following:

- ▶ the pertinent on-site rules and regulations for preventing fire and explosions as well as industrial safety regulations
- ▶ working on pressure equipment
- ▶ making pipe connections
- ▶ working with dangerous (hot or pressurized) fluids
- ▶ lifting and transporting loads
- ▶ observing all notes and instructions in this installation & operating manual and the applicable documents

Protective gear

The operator must ensure that anyone working on the equipment must wear the required protective clothing and safety gear stipulated for the site of installation. The protective clothing must be suitable for the used media and must protect the wearer against safety and health hazards associated with a particular job to be carried out at the site of installation. Protective clothing & equipment must provide protection from potential hazards, in particular from injuries to:

- ▶ Head
- ▶ Eyes
- ▶ Body
- ▶ Hand
- ▶ Feet
- ▶ Hearing

Note that this list is not exhaustive. The operator must establish personal protective equipment guidelines and specify any additional protective gear that is required if the worker is exposed to a specific risk at the site of installation.

Typographic features of warning notes



DANGER

Notes with the heading **DANGER** warn against imminent dangerous situations that can lead to death or serious injuries.



WARNING

Notes with the heading **WARNING** warn against possibly dangerous situations that could lead to death or serious injuries.



CAUTION

Notes with the heading **CAUTION** warn against dangerous situations that could lead to minor or moderate injuries.

Formatting features for warnings of property damage

Attention!

This information warns of a situation leading to property damage.

Description

Scope of supply and equipment specification

Scope of supply

Our equipment is delivered packed and ready for assembly.

Equipment specification

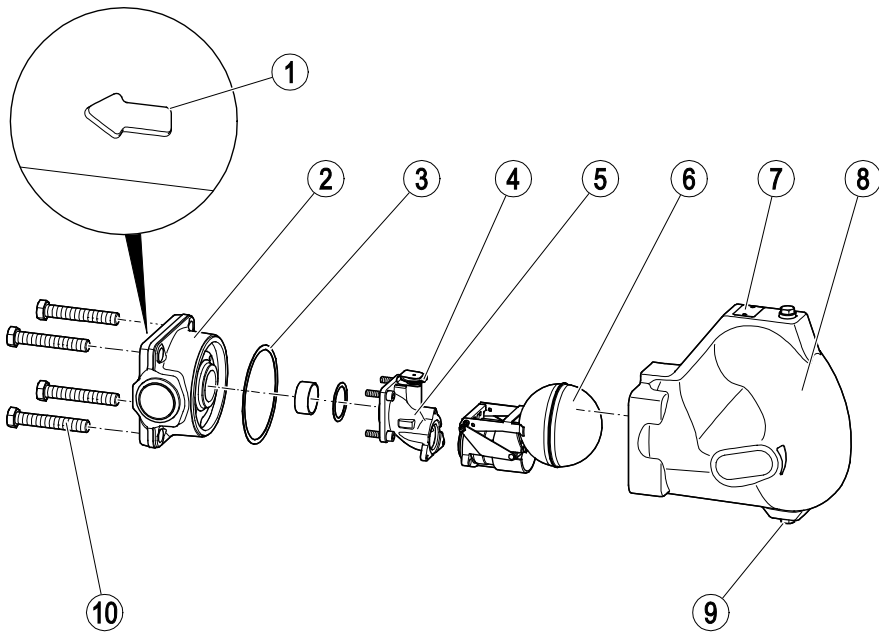

Item no.	Designation
1	Direction of flow arrow
2	Body
3	Body gasket
4	Capsule support with membrane regulator capsule
5	Adapter (shown here: control unit DUPLEX)

Item no.	Designation
6	Control unit
7	Name plate
8	Cover (shown here: standard cover)
9	Drain with sealing plug
10	Hexagon-head cap screws (4 pcs.)

Optional extras

The following items are available as optional extra:

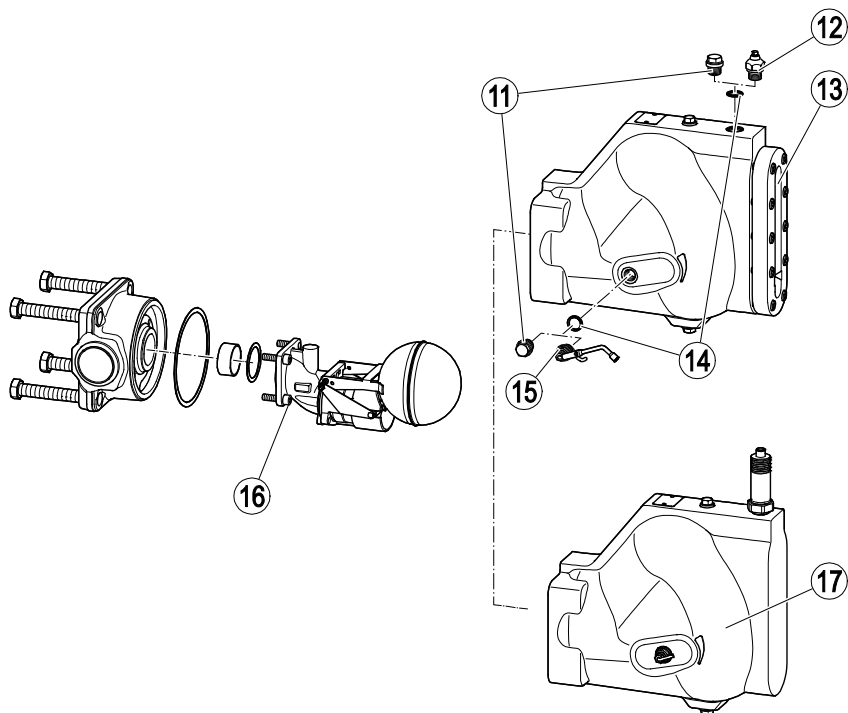

Item no.	Designation
11	Sealing plug
12	Hand-vent valve with socket spanner (socket spanner not shown) The vent hole in the cover for the hand-vent valve can also be used for connecting a balance line.
13	Cover with integrated reflexion water level sightglass for checking the performance

Item no.	Designation
14	Gasket
15	Float-lifting lever with socket spanner
16	Adaptor with control unit SIMPLEX
17	Cover with connections for electrodes NRG 16-19 or NRG 16-27



In equipment with control unit SIMPLEX the hand-vent valve is included as standard.

The different equipment versions allow you to adjust the flow direction of the equipment to the flow pattern of your installation. The flow arrow must correspond to the direction of the fluid flow. The following positions of installation are possible:

- ▶ "v" for installation in vertical pipework with downward flow
- ▶ "hl" for flow from right to left (when viewed from the body end)
- ▶ "hr" for flow from left to right (when viewed from the body end)

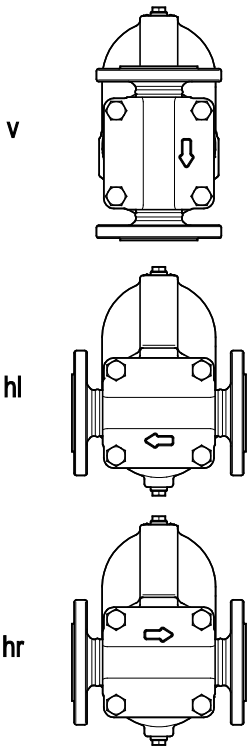

End connections

The equipment is available with the following end connections:

- ▶ Flanges
- ▶ Screwed sockets
- ▶ Socket-weld ends
- ▶ Butt-weld ends via transition pieces

i Screwed sockets are only available for sizes DN 40 and 50.

Name plate

The following items are indicated on the name plate:

- ▶ Manufacturer
- ▶ Type designation
- ▶ Design
- ▶ Nominal size
- ▶ Pressure rating
- ▶ Design temperature
- ▶ Design pressure
- ▶ Max. service temperature
- ▶ Max. admissible differential pressure
- ▶ CE marking
- ▶ Date of manufacturing
- ▶ Material number

The following items are indicated on the equipment body:

- ▶ Material
- ▶ Batch code
- ▶ Direction of flow

The following items are indicated on the end connections:

- ▶ Flange size
- ▶ Flange face type (RJ number)
- ▶ Thread type



The limiting conditions and pressure & temperature ratings specified in this installation manual are applicable for standard equipment. Note that these values may differ for modified or customized equipment.

All equipment specific values are indicated on the nameplate.

Application of European Directives

Pressure Equipment Directive

The equipment conforms to this directive (see "Manufacturer's Declaration" section) and can be used for the following media:

UNA 45 MAX

- ▶ Fluids of group 2

UNA 46 MAX and UNA 46A MAX

- ▶ Fluids of group 1
- ▶ Fluids of group 2

ATEX Directive

The equipment does not have its own potential ignition source and is not subject to this directive (see "Manufacturer's Declaration" section).

When installed, static electricity may arise between the equipment and the connected system.

When used in potentially explosive atmospheres, the plant manufacturer or plant operator is responsible for discharging or preventing possible static charge.

If it is possible for medium to escape, e.g. through actuating mechanisms or leaks in threaded joints, the plant manufacturer or plant operator must take this into consideration when dividing the area into zones.

Task and function

Purpose

UNA 45 MAX, UNA 46 MAX and UNA 46A MAX are items of equipment for the steam process designed for the effective removal of condensate from steam.

Equipment type UNA 45 MAX can also be used for removing condensate from compressed air systems.

Equipment type UNA 46 MAX and UNA 46A MAX can also be used for removing condensate from gases or gas mixtures.

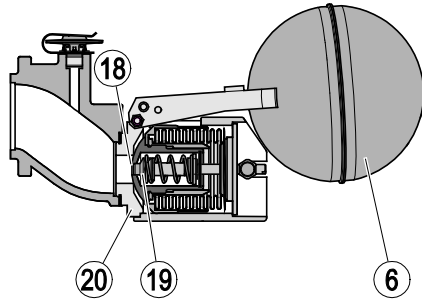

Function

A ball float opens the orifice as a function of the liquid level, thereby controlling the condensate flowrate to be discharged. The max. discharge capacity depends on the size of the fully open orifice (0).

The float (6) rises with the liquid level and pulls the nozzle stem (19) off the pilot valve (18), allowing a small amount of fluid to flow through the pilot valve.

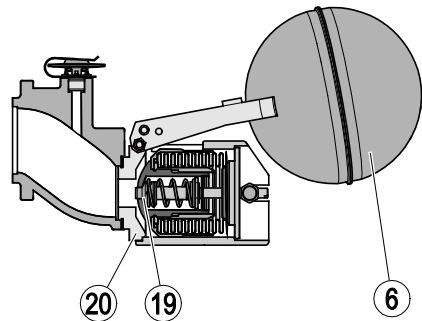

The fluid compresses the bellows of the control unit and, as a consequence, the discharge orifice (20) is completely uncovered.

Equipment with control unit SIMPLEX is particularly suitable for cold condensates and superheated steam.

Equipment with control unit DUPLEX may also be used for air venting the installation. The control unit DUPLEX consists of a float and a temperature dependent air-venting facility. The air venting is controlled by the membrane regulator. Equipment with this type of control unit is particularly suitable for saturated steam systems. Do not expose the membrane regulator capsule of the DUPLEX control unit to superheat conditions above 5 K.

The optional float-lifting lever allows you to lift the float manually.

The optional hand-vent valve allows you to air vent the pipe manually.

Storing and transporting the equipment

Attention!

Equipment can be damaged if stored or transported improperly.

- Close all openings with the sealing plugs or covers supplied with the equipment or use similar sealing covers.
- Protect the equipment against moisture and corrosive atmospheres.
- Please contact the manufacturer if the specified transport and/or storage requirements cannot be met.

Storing the equipment

- Please observe the following items when storing the equipment:
 - ▶ Do not store the equipment for more than 12 months.
 - ▶ Use the supplied sealing plugs or other suitable seal caps in order to seal off all openings of the equipment.
 - ▶ Protect the sealing surfaces and contact areas against mechanical damage.
 - ▶ Protect the equipment and all components against hard shocks and impacts.
 - ▶ Store the equipment only in closed rooms that meet the following environmental conditions:
 - ▶ Air humidity below 50 %, not condensing
 - ▶ Indoor air: clean, salt-free and non-corrosive
 - ▶ Temperature 5–40 °C.
- Make sure that all these requirements are always met when storing the equipment.
- Please contact the manufacturer if you cannot comply with the recommended storage conditions.

Transporting the equipment



CAUTION

Do not drop the equipment. If it falls down it may cause bruises and injuries.

- To transport and mount the equipment safely use suitable lifting gear.
- Connect the noose strap of the lifting gear to the body.
- Provide sufficient support for the equipment during transport and installation.
- Wear protective safety footwear.

Lightweight equipment may be transported and mounted without using any lifting gear.

To lift equipment the weight of which exceeds approx. 25 kg, you need the help of a second person or suitable lifting gear.

Your physical strength and on-site regulations and conditions determine what weight can be lifted and if support is required.

- Meet the requirements for storage also when transporting the equipment.
- Prior to transport seal off connections with sealing plugs.



If you do not have the sealing plugs supplied with the equipment use appropriate seal caps to seal off the connections.

- For short distances (only a few metres) you can transport the equipment unpacked.
- When transporting the equipment over larger distances use the original packaging.
- If you do not have the original packaging use a box that protects the equipment adequately against corrosion and physical damage.



For a short period of time the equipment may be transported even if the temperature is below 0 °C, provided that the equipment is completely empty and dry.

Mounting and connecting the equipment

Preparing installation

- Take the equipment out of the transport packaging.
- Check the equipment for transport damage.
- Contact the manufacturer if you detect any kind of shipping damage.

When supplied by the factory, the connections may be sealed off with sealing plugs.

- Remove sealing plugs before mounting the equipment.
- Keep the sealing plugs and the packing for further use.



DANGER

Personnel working on pipes are exposed to safety risks and may suffer severe injuries, poisoning or even loss of life.

- Make sure that no hot or hazardous fluid is in the equipment or the pipes.
- Make sure that the pipes upstream and downstream of the equipment are depressurised.
- Make sure that the installation is switched off and protected against unauthorised or unintended activation.
- Make sure that the equipment and the pipes have cooled down to room temperatures.
- Wear protective clothing that is suitable for the fluid and, if necessary, wear protective gear.

For more information on suitable protective clothing and safety gear refer to the safety data sheet of the fluid in question.

- Drain pipes until they are empty.
- Switch the installation off and protect it against unauthorised or unintended re-activation.

Orientation of the equipment

The different equipment versions allow you to adjust the flow direction of the equipment to the flow pattern of your installation. The following positions of installation are possible:

- ▶ with horizontal connections "hl" and "hr" for installation in horizontal pipes
- ▶ with vertical connections "v" for installation in vertical pipework with downward flow

Attention!

Malfunctions may occur if the control unit is installed incorrectly.

- ▶ When installing the equipment make sure that the name plate points upwards and the float arm is free to move up and down.
- ▶ Make sure that the flow arrow on the equipment body matches the direction of flow in the pipe.

To avoid malfunctions make sure the following requirements are met when mounting the equipment:

- ▶ The flow arrow on the equipment body must match the fluid flow direction.
- ▶ The name plate on the cover must point upwards.
- ▶ Contact the manufacturer if you want to mount the equipment in a different position of installation.

To change the position of installation remove the adapter with the control unit attached to it. In equipment with control unit DUPLEX the capsule support is also attached to the adapter.

To remove the adapter proceed as follows:

- ▶ Detach the cover from the body as described on page 19.
- ▶ Remove the four socket-head cap screws (21) from the adapter (5).
- ▶ Remove the adapter with the control unit from the body (2).

- ▶ Remove the adapter gasket (22).
- ▶ For the disposal of the adapter gasket observe the pertinent on-site regulations concerning waste disposal.

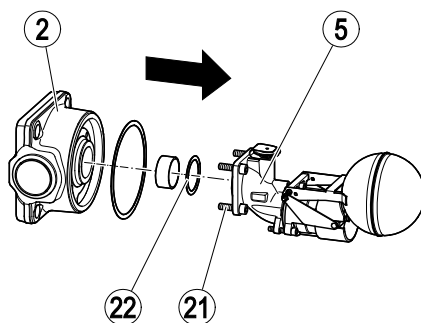

- ▶ Check all removed parts for signs of damage.
- ▶ Replace all worn or damaged parts.
- ▶ Clean all dirty parts.
- ▶ Apply high-resistant lubricant to all threads, bearing faces of screws, nuts and bolts.

The lubricant must have the same properties as OKS® 217.

Attention!

Equipment may leak if the gasket is damaged.

- ▶ Replace all gaskets that you loosen during your work.
- ▶ Use only new gaskets of the same type.

- Replace all gaskets with new ones of the same type.
- Turn the adapter (5) by 90° or 180° into the desired position of installation.
- Make sure that the float arm is free to move up and down.
- Put a new adapter gasket (22) onto the body.
- Make sure that the adapter is not tilted or skewed when fitted into the body (2).
- Fix the adapter in place using the four socket-head cap screws (21).
- Tighten the socket-head cap screws with a torque of 14 Nm.

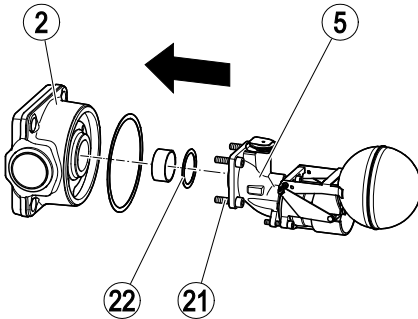

- Attach the cover to the body as described on page 23.

Connecting the equipment



DANGER

Incorrectly connected equipment can cause fatal accidents or severe injuries.

- Make sure that only qualified skilled personnel connect the equipment to pipes.
- Make sure that the flow arrow on the equipment body matches the direction of flow in the pipe.

Specialist personnel must be highly qualified and fully experienced in making pipe connections for the respective type of end connection.



CAUTION

Do not drop the equipment. If it falls down it may cause bruises and injuries.

- To transport and mount the equipment safely use suitable lifting gear.
- Connect the noose strap of the lifting gear to the body.
- Provide sufficient support for the equipment during transport and installation.
- Wear protective safety footwear.

Lightweight equipment may be transported and mounted without using any lifting gear.

To lift equipment the weight of which exceeds approx. 25 kg, you need the help of a second person or suitable lifting gear.

Your physical strength and on-site regulations and conditions determine what weight can be lifted and if support is required.

Attention!

Equipment will be damaged if the end connections are undersized.

- Make sure that the connections are strong and rigid enough to support the weight of the equipment and to withstand the forces that occur during operation.

Consider space required for servicing the equipment and/or exchanging components and observe the necessary withdrawal distance to remove the cover. For more information on the required withdrawal distances see section "*Dimensions and weights*" on page 38.



Some applications require that the equipment is fitted with an air-balance pipe:
Equipment with control unit SIMPLEX MAX, float traps for compressed air line drainage and equipment installed in plants where condensate is lifted upstream of the equipment.

- In this case connect the air balance pipe to the bore on top of the cover.
- Make sure that the pipe system of the plant is clean.
- Make sure that the equipment is free from foreign matter.
- Mount the equipment in the desired installation position.
- Make sure that the pipes meet the following requirements:
 - ◆ The layout of the pipelines must prevent the formation of water pockets.
 - ◆ The pipeline must have a gradient so that the condensate is free to fall towards the equipment
 - ◆ The cross section of the air balance pipe must be at least DN 8 (1/4 ") .
 - ◆ If the equipment is fitted with control unit SIMPLEX, an air balance pipe must be connected to the vent hole for the hand-vent valve. The air balance pipe must have the following end connection dimensions:
 - ◆ Standard cover and sightglass cover: G3/8 "
 - ◆ Cover with electrode connections: G1/4 "
- If one or more of the above mentioned requirements cannot be met, please contact our Technical Service or authorized agency in your country.
- Connect the end connections of the equipment properly to the pipes.

- If necessary, connect the air balance pipe to the equipment as shown in the following drawing.

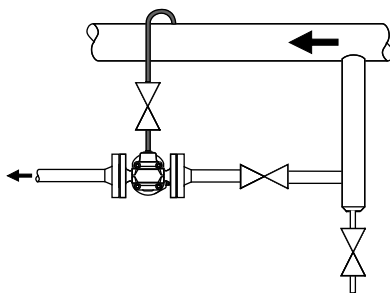

- Make sure that the equipment is safely mounted and that all connections are made correctly.

Mounting the measuring electrode

If the equipment has a cover with electrode connections you can attach one or two measuring electrodes of the following type:

- ▶ To detect banking-up of condensate: NRG 16-19 or NRG 16-27 installed on top of the body (24)
- ▶ To detect loss of water seal: NRG16-19 or NRG16-27 installed at the side of the body (25)

If the equipment is fitted with a standard cover you can fit the measuring electrode laterally.

The following tool is required for installation work:

- ▶ Combination spanner to DIN 3113 form B:
 - ▶ Connection G $\frac{1}{4}$ ": A. F. 13
 - ▶ Connection G $\frac{3}{8}$ ": A. F. 17
 - ▶ NRG16-19: A. F. 22
 - ▶ NRG16-27 (new): A. F. 27
 - ▶ NRG16-27 (old): A. F. 32
- ▶ Torque spanner (US: wrench) 60-120 Nm to DIN ISO 6789

Attention!

The measuring electrode might get damaged if it is mounted incorrectly.

- ▶ Do not insulate the equipment after installation of the measuring electrode.
- ▶ Observe and follow all instructions given in the installation & operating manual for the measuring electrode.

To mount the measuring electrodes proceed as follows:

- ▶ Apply heat resistant lubricant to the threads and the terminal box side of the measuring electrode.

The lubricant must have the same properties as OKS®217.

- ▶ Use a suitable combination spanner to screw the measuring electrode into the desired connection (24 or 25) on the body.

- ▶ Tighten the measuring electrode with a torque of 75 Nm.
- ▶ Connect the body to the pipework as described in the previous section.
- ▶ Attach an air balance pipe to the connection G $\frac{1}{4}$ " (23).

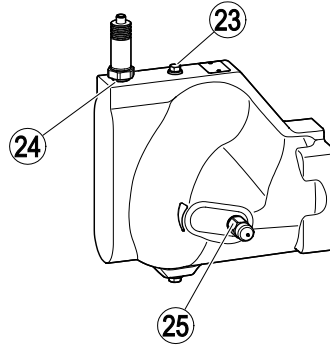

Before mounting measuring electrodes please note:

If a measuring electrode type NRG 16-27 is mounted on top of the body, only a screwed union for a pipe with cross section 8 mm will fit into the bore G $\frac{1}{4}$ ". If a screwed union for a pipe with cross section 10 mm were used, the hexagon connection would press onto the measuring electrode.

Operation



WARNING

Hot liquids and steam can cause scalding.

- Wear protective clothing that is suitable for the fluid and, if necessary, wear protective gear.

Protective clothing and protective gear must protect the whole body against contact with escaping hot steam.

For more information on suitable protective clothing and safety gear refer to the safety data sheet of the fluid in question.

During operation you can undertake the following work:

- ▶ Open and close the optional hand-vent valve
- ▶ Open and close the optional manual float-lifting lever

To do this, use the socket spanner (stock code # 526110) supplied with the equipment.

The optional hand vent valve allows manual air venting.

- To air vent the equipment turn the hand-vent valve (viewed from top) anticlockwise.
- To close the hand-vent valve after air-venting turn it clockwise.
- Fasten the hand-vent valve hand tight.

The optional float-lifting lever allows the float to be manually lifted irrespective of the liquid level. It can be used to purge any dirt away from the seat area and out of the equipment by opening the orifice and draining the liquid.

The cast arrow on the body indicates the correct direction of rotation.

- ▶ To open the orifice turn the socket spanner from the tip of the arrow towards the end of the arrow.

- ▶ To close the orifice turn the socket spanner from the end of the arrow towards the tip of the arrow.

After operation



DANGER

If fluid escapes personnel may suffer severe injuries, poisoning or even loss of life.

- After working on the equipment make sure that all connections and valves are tight.
- Make sure that the gaskets of the body are leakproof.



DANGER

Personnel working on pipes are exposed to safety risks and may suffer severe injuries, poisoning or even loss of life.

- Make sure that no hot or hazardous fluid is in the equipment or the pipes.
- Make sure that the pipes upstream and downstream of the equipment are depressurised.
- Make sure that the installation is switched off and protected against unauthorised or unintended activation.
- Make sure that the equipment and the pipes have cooled down to room temperatures.
- Wear protective clothing that is suitable for the fluid and, if necessary, wear protective gear.

For more information on suitable protective clothing and safety gear refer to the safety data sheet of the fluid in question.



DANGER

If the equipment is used in contaminated areas there is a risk of severe injuries or death caused by harmful substances in or on the equipment.

- Only qualified personnel are allowed to perform work on contaminated equipment.
- Always wear the protective clothing prescribed for contaminated areas when working on the equipment.
- Make sure that the equipment is completely decontaminated before carrying out any service work.
- Follow the pertinent instructions for handling the hazardous substances in question.

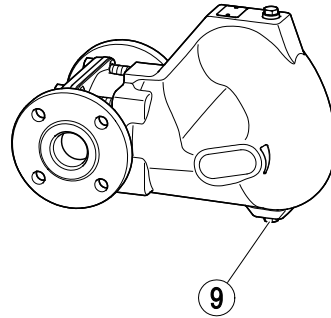

Removing external dirt deposits

- To remove dirt deposits rinse the equipment with fresh water and wipe it with a clean, lint-free cloth.
- To remove any persistent residues use a cleaning agent that is suitable for the material and carefully wipe the equipment with a clean, lint-free cloth.

Attention!

Frost damage may occur when the installation is shut down.

- Drain the equipment if ambient temperatures below 0 °C (frost) are to be expected.
- Provide a device that collects any fluid that may escape.
- Remove the sealing plug (9) at the bottom of the body.
- Allow all liquid to escape and wait until the body is completely empty.
- To seal the drain hole screw in the sealing plug and tighten it with a torque of 75 Nm.

Maintaining the equipment

For work on the equipment you will need the following tools:

- ▶ Combination spanner form B to DIN 3113, sizes
 - ▶ A. F. 17
 - ▶ A. F. 22
 - ▶ A. F. 24
 - ▶ A. F. 27
 - ▶ A. F. 32 for equipment with measuring electrodes
- ▶ Torque spanner to DIN ISO 6789
 - ▶ up to 10 Nm
 - ▶ 10 – 60 Nm
 - ▶ 60 – 120 Nm
 - ▶ 120 – 300 Nm
- ▶ Allen key to DIN ISO 2936, sizes
 - ▶ A. F. 5
 - ▶ A. F. 6
- ▶ Screwdriver 5.5/125 to DIN 5265



Malfunctions may occur if the equipment is used with different types of condensate. The following condensates in particular cause problems:

- very oily condensates
- condensates that resinify or become gummy
- condensates that recrystallize
- condensates that contain solid matter.

In these cases check the equipment at regular intervals for contamination and, if necessary, remove dirt deposits.

To reduce contamination we recommend installing a sedimentation vessel or a dirt pocket arrangement upstream of the equipment.

Normally you do not have to clean the internal parts of the equipment.

To clean the equipment completely take off the cover and remove the control unit.



The following drawings show equipment type UNA 45 MAX with standard cover.

Removing cover



Remove the measuring electrode(s) if mounted, before lifting off the cover.

- Use a suitable combination spanner to DIN 3113, form B, to remove the measuring electrode.
- Remove the four hexagon-head cap screws (10) in the body.
- Lift the cover (8) off the body (2).
- Remove the body gasket (3).
- For the disposal of the body gasket observe the pertinent on-site regulations concerning waste disposal.

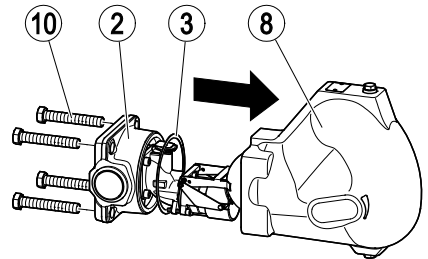

Removing control unit

- Detach the cover from the body as described on page 19.
- Remove the three socket-head cap screws (27).
- Remove the control unit (6) together with the orifice (28) from the adapter (5).
- Remove the gasket (26) for the control unit.
- For the disposal of the gaskets observe the pertinent on-site regulations concerning waste disposal.

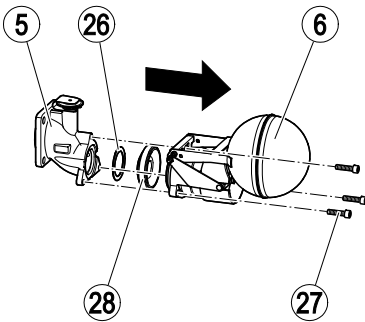

Cleaning the equipment

Check the equipment at regular intervals for contamination. The intervals depend on the amount of dirt in the system. The operator must determine the maintenance intervals.

- Remove any parts that are dirty and cannot be cleaned properly.

To clean the inside of the equipment proceed as follows:

- Detach the cover from the body as described on page 19.
- Remove the control unit as described on page 20.
- To remove dirt deposits rinse the equipment with fresh water and wipe it with a clean, lint-free cloth.
- To remove any persistent residues use a cleaning agent that is suitable for the material and carefully wipe the equipment with a clean, lint-free cloth.
- Fix the control unit to the body as described on page 22.
- Attach the cover to the body as described on page 23.

Cleaning and checking the membrane regulator capsule

To clean the membrane regulator capsule of equipment with a DUPLEX control unit proceed as follows:

- Detach the cover from the body as described on page 19.
- Remove the control unit as described on page 20.
- Remove the membrane regulator capsule as described in section "*Exchanging the membrane regulator capsule*" on page 30.
- Clean the membrane regulator capsule with cold clean water.
- Use a depth gauge to check the dimension x of the membrane regulator capsule as shown in the following drawing.

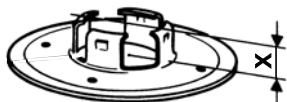

The membrane regulator capsule is intact if dimension x exceeds 4.0 mm.

- Discard and replace defective membrane regulator capsule with a new one.
- Mount the membrane regulator capsule as described in section "*Exchanging the membrane regulator capsule*" on page 30.

Fitting control unit in place

Attention!

Malfunctions may occur if the control unit is installed incorrectly.

- When installing the equipment make sure that the name plate points upwards and the float arm is free to move up and down.
- Make sure that the flow arrow on the equipment body matches the direction of flow in the pipe.

-
- Check all removed parts for signs of damage.
 - Replace all worn or damaged parts.
 - Clean all dirty parts.
 - Apply high-resistant lubricant to all threads, bearing faces of screws, nuts and bolts.

The lubricant must have the same properties as OKS® 217.

Attention!

Equipment may leak if the gasket is damaged.

- Replace all gaskets that you loosen during your work.
 - Use only new gaskets of the same type.
-
- Replace all gaskets with new ones of the same type.
 - Insert a new gasket (26) for the control unit into the adapter (5).
 - Use the three socket-head cap screws (27) to fix the control unit (6) with the orifice (28) to the adapter.
 - Tighten the socket-head cap screws with a torque of 7 Nm.

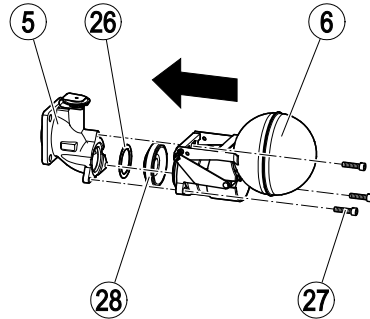

- Attach the cover to the body as described on page 23.

Mounting cover

Attention!

Equipment may leak if the gasket is damaged.

- It is therefore essential that you always insert a new gasket before re-attaching the cover.
 - Make sure that the cover is not tilted or skewed when refitted.
-
- Clean the gasket surfaces of the cover and body.
 - Apply heat resistant lubricant to the threads and bearing faces of the screws.
- The lubricant must have the same properties as OKS® 217.
- Put a new body gasket (3) onto the body (2).
 - Insert the four hexagon-head cap screws (10) into the bores of the body.

- Refit the cover (8) onto the body such that the name plate (7) points upwards.
- Tighten the hexagon-head cap screws with a torque of 140 Nm.

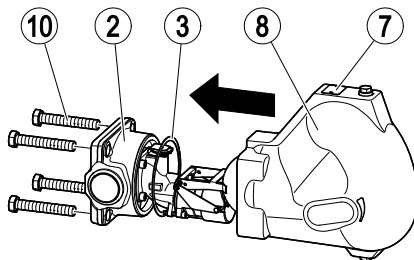

- If necessary, mount the measuring electrode as described on page 16.

Servicing the equipment and installing spare parts

You may exchange the following component parts
in case of wear or damage:

UNA 45 MAX, UNA 46 MAX and UNA 46A MAX with standard cover

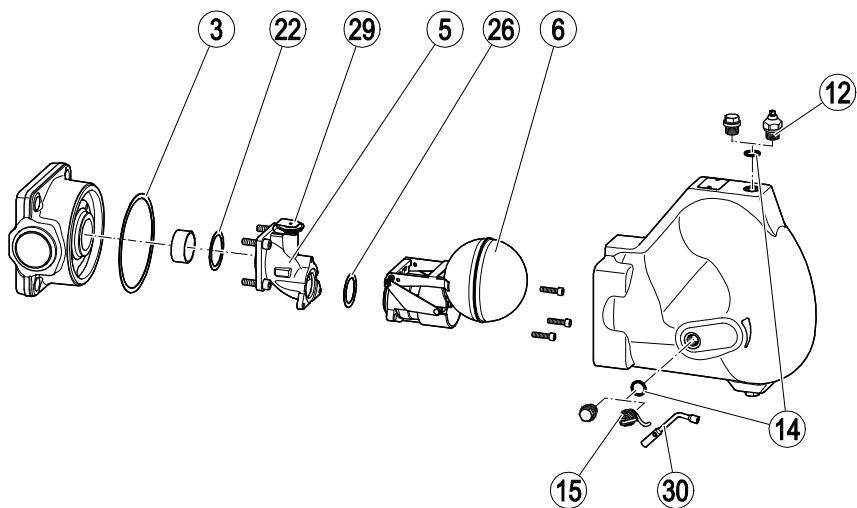

Spare parts for equipment with standard cover			
Item no.	Designation	Orifice	Stock code #
3, 6, 22, 26	Control unit, cpl. with body gasket, adapter gasket and gasket for control unit	4	560690
		8	560691
		13	560692
		22	560693
		32	560694
3, 29	Membrane regulator capsule 5N2, cpl. with body gasket	all	560687
12, 14, 30	Hand-vent valve, cpl. with joint ring and socket spanner	all	560676
14, 15, 30	Float lifting lever, cpl. with joint ring and socket spanner	all	560678
3	Body gasket ¹	all	560680
22	Adapter gasket ¹	all	560682
14	Joint ring for sealing plug $\frac{3}{8}$ ", manual float-lifting lever, hand-vent valve ¹	all	560486 ² or 560514 ²
26	Gasket for control unit ³	all	560547
3, 14, 22, 26	Gasket set ⁴	all	560684
30	Socket spanner	all	560700

- 1 Delivery quantity: 20 pcs.
- 2 560486: Material 1.4301, 560514: Material 1.4571
- 3 Delivery quantity: 10 pcs.
- 4 Comprises:
 - ▶ 4 joint rings $\frac{3}{8}$ "
 - ▶ 1 body gasket
 - ▶ 1 gasket for control unit
 - ▶ 1 adapter gasket

UNA 45 MAX with cover for installing electrodes

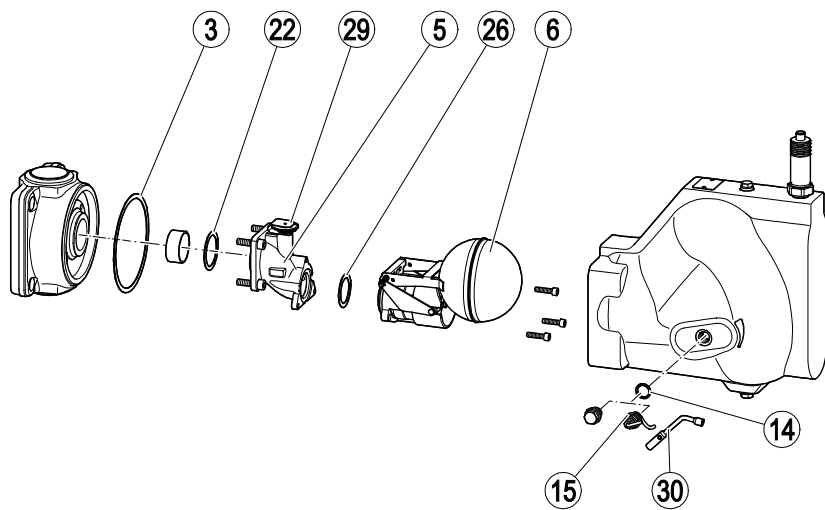

Spare parts for equipment with cover for installing electrodes			
Item no.	Designation	Orifice	Stock code #
3, 6, 22, 26	Control unit, cpl. with body gasket, adapter gasket and gasket for control unit	4	560690
		8	560691
		13	560692
		22	560693
		32	560694
3, 29	Membrane regulator capsule 5N2, cpl. with body gasket	all	560687
14, 15, 30	Float lifting lever, cpl. with joint ring and socket spanner	all	560678
3	Body gasket ¹	all	560680
22	Adapter gasket ¹	all	560682
14	Joint ring for sealing plug 3/8", manual float-lifting lever, hand-vent valve ¹	all	560486 ² or 560514 ²
26	Gasket for control unit ³	all	560547
3, 14, 22, 26	Gasket set ⁴	all	560684
30	Socket spanner	all	560700

- 1 Delivery quantity: 20 pcs.
- 2 560486: Material 1.4301, 560514: Material 1.4571
- 3 Delivery quantity: 10 pcs.
- 4 Comprises:
 - ▶ 4 joint rings 3/8"
 - ▶ 1 joint ring 1/4"
 - ▶ 1 body gasket
 - ▶ 1 gasket for control unit
 - ▶ 1 adapter gasket

UNA 45 MAX with sightglass cover

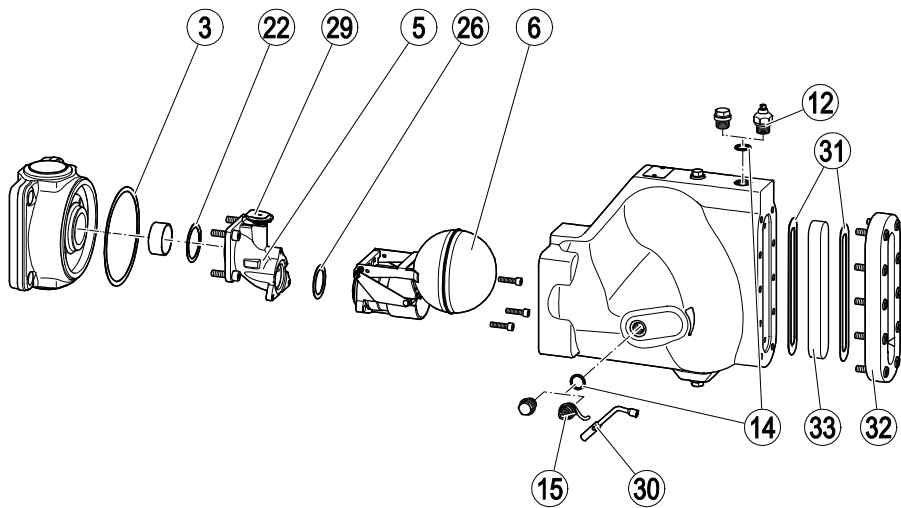

Spare parts for equipment with sightglass cover			
Item no.	Designation	Orifice	Stock code #
3, 6, 22, 26	Control unit, cpl. with body gasket, adapter gasket and gasket for control unit	4	560690
		8	560691
		13	560692
3, 29	Membrane regulator capsule 5N2, cpl. with body gasket	all	560687
12, 14, 30	Hand-vent valve, cpl. with joint ring and socket spanner	all	560676
14, 15, 30	Float lifting lever, cpl. with joint ring and socket spanner	all	560678
3	Body gasket ¹	all	560680
22	Adapter gasket ¹	all	560682
14	Joint ring for sealing plug 3/8", manual float-lifting lever, hand-vent valve ¹	all	560486 ² or 560514 ²
26	Gasket for control unit ³	all	560547
31, 33	Reflexion water level gauge with 2 gaskets	all	560480
30	Socket spanner	all	560700

- 1 Delivery quantity: 20 pcs.
- 2 560486: Material 1.4301, 560514: Material 1.4571
- 3 Delivery quantity: 10 pcs.

Exchanging the control unit

- Detach the cover from the body as described on page 19.
- Remove the control unit as described on page 20.
- Fix the control unit to the body as described on page 22.
- Attach the cover to the body as described on page 23.

Exchanging the membrane regulator capsule

- Detach the cover from the body as described on page 19.
- Push the mounting clip (35) off the control unit (1.).
- Pull the membrane regulator capsule (29) upwards and off the seat (34) in the adapter (5) (2.).

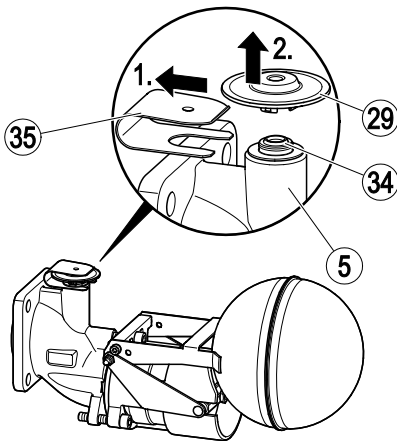

Install the new membrane regulator capsule as follows:

- Press the membrane regulator capsule onto the seat until it snaps into place.
- Slip the mounting clip over the membrane regulator capsule.
- Attach the cover to the body as described on page 23.

Replacing the sightglass of the sightglass cover

- Remove the socket-head cap screws (36).
- Detach the flange (32) from the sightglass cover (13).
- Remove the outer gasket (31).
- Remove the sightglass (33).
- Remove the inner gasket (31).
- For the disposal of the gaskets observe the pertinent on-site regulations concerning waste disposal.

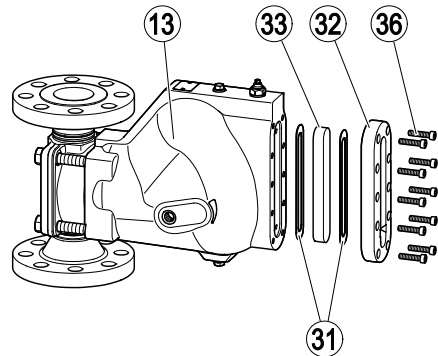

Attention!

Equipment may leak if the gasket is damaged.

- Replace all gaskets that you loosen during your work.
 - Use only new gaskets of the same type.
-
- Apply heat resistant lubricant to the threads and bearing faces of the socket-head cap screws. The lubricant must have the same properties as OKS® 217.
 - Insert a new gasket in the sightglass cover.
 - Insert a new sightglass.
 - Put a new gasket on the sightglass.
 - Screw the socket-head cap screws into the bores of the flange.

- Tighten the socket-head cap screws alternately and in several steps with a torque of 12 Nm.

Exchanging the float-lifting lever

To replace a damaged float-lifting lever proceed as follows:

- If necessary remove the socket spanner.
- Undo the hexagon-head cap screw on the float-lifting lever (15).
- Detach the float-lifting lever from the body.

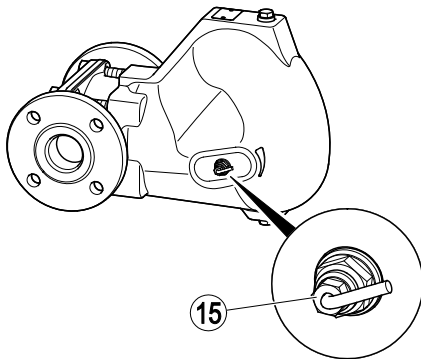

- For the disposal of the gaskets observe the pertinent on-site regulations concerning waste disposal.

Attention!

Equipment may leak if the gasket is damaged.

- Replace all gaskets that you loosen during your work.
- Use only new gaskets of the same type.

Attention!

The packing rings may get damaged.

- Make sure you do not damage the packing rings during installation and removal.
- When installing and removing the packing rings never use force. Make sure that the packing rings are correctly positioned and not skewed.

- Insert the gasket supplied with the float-lifting lever into the tapped hole in the body.
- Screw the new float-lifting lever into the tapped hole.
- Tighten the hexagon-head cap screw of the float-lifting lever with a torque of 75 Nm an.

Exchanging the hand-vent valve

To replace a damaged hand-vent valve proceed as follows:

- If necessary remove the socket spanner.
- Detach the hand-vent valve from the tapped hole in the body.
- For the disposal of the gaskets observe the pertinent on-site regulations concerning waste disposal.

Attention!

Equipment may leak if the gasket is damaged.

- Replace all gaskets that you loosen during your work.
- Use only new gaskets of the same type.

- Insert the gasket supplied with the hand-vent valve into the tapped hole in the body.
- Screw the new hand-vent valve into the tapped hole.
- Tighten the hand-vent valve with a torque of 75 Nm.

Troubleshooting

Problem	Cause	Remedy
The sightglass or water level gauge does not offer an unambiguous evaluation of the operating condition.	The sightglass or water level gauge is dirty, worn or scratched.	Replace the sightglass or water level gauge.
The equipment is blowing off live steam.	The external bypass is open.	Completely close the external bypass.
The equipment is blowing off live steam.	The control unit is damaged or worn.	Replace the control unit.
The equipment is blowing off live steam.	Dirt deposits, precipitated solids or foreign particles have accumulated in the equipment.	If fitted, operate the float-lifting lever. Clean the pipes. Clean all internals. If necessary, replace internals or the whole equipment.
The equipment is cold or only warm to the touch.	The sealing plugs are still attached to the connections.	Remove the equipment. Remove the sealing plugs. Mount the equipment.
The discharge capacity is too low. The equipment is cold or only warm to the touch.	The shut-off valves for fluid flow are closed.	Fully open the shut-off valves.
The discharge capacity is too low. The equipment is cold or only warm to the touch. Insufficient thermal output of the user.	The inlet, outlet or the equipment is dirty.	If fitted, operate the float-lifting lever. Clean the pipes. Clean all internals. If necessary, replace internals or the whole equipment.
The discharge capacity is too low. Insufficient thermal output of the user.	The equipment is undersized.	Use equipment with a larger discharge capacity.
The discharge capacity is too low. Insufficient thermal output of the user.	Steam pressure and condensate flowrate fluctuate considerably. The pressure upstream of the equipment is too low for the used equipment type.	Use equipment with a larger discharge capacity. If necessary, use a pump steam trap or a condensate return unit.

Problem	Cause	Remedy
The discharge capacity is too low. Insufficient thermal output of the user.	The differential pressure is too small.	Increase the steam pressure. Lower the pressure in the condensate line. Use equipment with a larger discharge capacity. If necessary, use a pump steam trap or a condensate return unit.
The discharge capacity is too low. Insufficient thermal output of the user.	Insufficient deaeration.	Connect an additional air vent.
The discharge capacity is too low. Insufficient thermal output of the user.	The pipes do not have a continuous fall in flow direction.	Make sure that the lines run with a continuous fall in flow direction.
Fluid escapes (equipment is leaking).	The body has been damaged by corrosion or erosion.	Replace the equipment with a new one. Use equipment made of material that is suitable for the application.
Fluid escapes (equipment is leaking).	The equipment has been damaged by waterhammer.	Replace the equipment with a new one. Take appropriate measures to protect the equipment against waterhammer. Use e. g. non-return valves or a pump steam trap.
Fluid escapes (equipment is leaking).	The equipment or the body is damaged.	Replace the equipment with a new one.
Fluid escapes (equipment is leaking).	A gasket is damaged.	Replace the gasket with a new one. Clean gasket seating surfaces.
Fluid escapes (equipment is leaking).	The connections are not tight.	Provide the connections with leakproof seals.
Fluid escapes (equipment is leaking).	The stuffing box packing has not been tightened enough.	Tighten the stuffing-box packing hand tight. Make sure that the stuffing box packing does not impair the movement of the internals.
Fluid escapes (equipment is leaking).	The stuffing-box packing is damaged.	Replace the stuffing-box packing.

Problem	Cause	Remedy
Fluid escapes (equipment is leaking).	The equipment has been damaged by frost.	Replace the equipment with a new one. When shutting down the installation make sure that all lines and the equipment are completely drained.

- If faults occur that are not listed above or cannot be corrected, please contact our Technical Service or authorized agency in your country.

Retighten the stuffing-box packing.

Retighten the stuffing-box packing if the equipment is leaking fluid at the float-lifting lever.

If you cannot prevent the stuffing-box packing from leaking fluid replace the whole float-lifting lever.

Tighten the stuffing-box packing until the following requirements are met:

- To do so follow the instructions given on page 31.

- ▶ The stuffing box must not leak.
- ▶ The movement of the float-lifting lever must not be impaired by the stuffing box.
- Fasten the hexagon-head cap screw on the float-lifting lever (15).
- Allow the fluid to flow through the equipment.
- Move the float-lifting lever several times over the full length.
- Make sure that the float-lifting lever can move freely.
- If necessary, slightly loosen the hexagon-head cap screw.

The stuffing-box packing is adjusted correctly if no fluid escapes and the float-lifting lever moves freely.

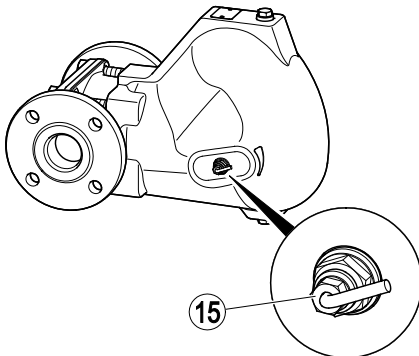

Putting the equipment out of operation

Removing harmful substances



DANGER

If the equipment is used in contaminated areas there is a risk of severe injuries or death caused by harmful substances in or on the equipment.

- Only qualified personnel are allowed to perform work on contaminated equipment.
- Always wear the protective clothing prescribed for contaminated areas when working on the equipment.
- Make sure that the equipment is completely decontaminated before carrying out any service work.
- Follow the pertinent instructions for handling the hazardous substances in question.

Qualified personnel must have extensive experience with and a working knowledge of:

- ◆ pertinent rules and regulations concerning handling hazardous substances
- ◆ special regulations for handling the hazardous substances encountered on site
- ◆ using the required personal protective equipment (PPE) and clothing



Caution

Environmental damage may be caused by poisonous fluid residues.

- Before disposing of the equipment make sure that it is clean and free of fluid residues.
- For the disposal of all materials observe the pertinent legal regulations concerning waste disposal.

- Remove all residues from the equipment.
- For the disposal of all residues observe the pertinent legal regulations concerning waste disposal.

Removing the equipment



DANGER

Personnel working on pipes are exposed to safety risks and may suffer severe injuries, poisoning or even loss of life.

- Make sure that no hot or hazardous fluid is in the equipment or the pipes.
- Make sure that the pipes upstream and downstream of the equipment are depressurised.
- Make sure that the installation is switched off and protected against unauthorised or unintended activation.
- Make sure that the equipment and the pipes have cooled down to room temperatures.
- Wear protective clothing that is suitable for the fluid and, if necessary, wear protective gear.

For more information on suitable protective clothing and safety gear refer to the safety data sheet of the fluid in question.



CAUTION

Risk of injuries if the equipment falls down.

- When removing the equipment make sure the it is safely held in place and cannot fall down.

Suitable measures are for instance:

- ▶ Equipment that is not too heavy may be supported by a second person.
- ▶ For heavy equipment use suitable lifting equipment of sufficient strength.
- Detach the end connections of the equipment from the pipes.
- Put the equipment onto a suitable base.
- Store the equipment as described in section "*Storing the equipment*" from page 11 onwards.

Re-using equipment after storage

Observe the following instructions if you want to remove the equipment and use it again somewhere else:

- ▶ Make sure that the equipment is free of any fluid residues.
- ▶ Make sure that all connections are in good condition and leak-free.
- ▶ If necessary re-work welded connections in order to ensure that they are in good working condition.
- Use the equipment only for its intended purpose and the service conditions for which it was specified.

Disposing of the equipment



Caution

Environmental damage may be caused by poisonous fluid residues.

- Before disposing of the equipment make sure that it is clean and free of fluid residues.
- For the disposal of all materials observe the pertinent legal regulations concerning waste disposal.

The equipment is made from the following materials:

Component part	Type	EN	ASTM
Body	UNA 45 MAX, UNA 46 MAX	1.0460	A105
	UNA 46A MAX	1.4404	A182-F316L
Cover	UNA 45 MAX, sightglass cover, cover for installing electrodes	5.3103	A395 ¹
	UNA 46 MAX	1.0619	SA216-WCB
	UNA 46A MAX	1.4408	A351-CF8M
Body gasket, controller gasket, adapter gasket, gasket for reflexion water level gauge	all	Graphite CrNi	
Membrane regulator capsule	all	Hastelloy / stainless steel	
Other components	all	Stainless steel	

1 Physical and chemical properties comply with EN grade. ASTM nearest equivalent grade is stated for guidance only.

Technical data

Dimensions and weights

The drawing shows equipment with standard cover and flanged connection for vertical downward flow.

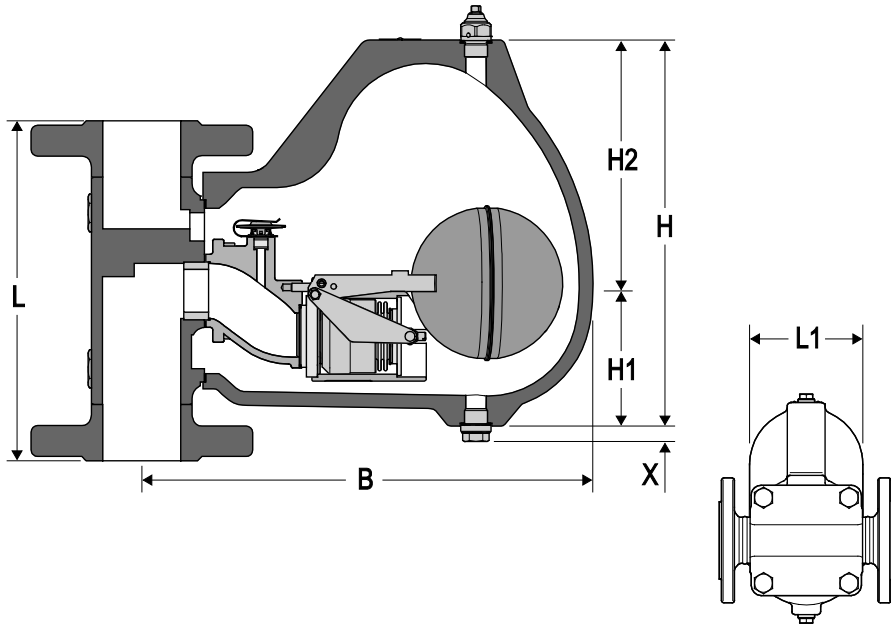

Equipment with flanges EN 1092-1 PN 10–40

	Type of cover	DN 40 (1½")	DN 50 (2")	DN 65 (2½")
L [mm (in)]	all	230 (9.1)		290 (11.4)
B [mm (in)]	Standard cover	328 (12.9)		
	Sightglass cover	370 (14.6)		
	Cover for mounting electrodes	343 (13.5)		
H1 [mm (in)]	all	98 (3.9)		
H2 [mm (in)]	all	182 (7.2) ¹		
H [mm (in)]	all	280 (11.0) ¹		
L1 [mm (in)]	all	160 (6.3) ²		
X [mm (in)]	all	13 (0.5)		
Weight [kg]	Standard cover	33.3	35.1	37.4
	Sightglass cover	37.5	39.0	41.3
	Cover for mounting electrodes	35.5	36.9	39.3
Weight [lb]	Standard cover	73.4	77.4	82.5
	Sightglass cover	82.7	86.0	91.0
	Cover for mounting electrodes	78.3	81.3	86.6

- 1 If equipped with hand-vent valve add 25 mm (1 in).
- 2 If equipped with float-lifting lever add 35 mm (1.4 in).

Equipment with flange ASME CL 150

	Type of cover	DN 40 (1½")	DN 50 (2")	DN 65 (2½")
L [mm (in)]	all	241 (9.5)	267 (10.5)	292 (11.5)
B [mm (in)]	Standard cover	328 (12.9)		
	Sightglass cover	370 (14.6)		
	Cover for mounting electrodes	343 (13.5)		
H1 [mm (in)]	all	98 (3.9)		
H2 [mm (in)]	all	182 (7.2) ¹		
H [mm (in)]	all	280 (11.0) ¹		
L1 [mm (in)]	all	160 (6.3) ²		
X [mm (in)]	all	13 (0.5)		
Weight [kg]	Standard cover	32.6	34.6	38.2
	Sightglass cover	36.5	38.5	42.1
	Cover for mounting electrodes	34.5	36.5	40.1
Weight [lb]	Standard cover	71.9	76.3	84.2
	Sightglass cover	80.5	84.9	92.8
	Cover for mounting electrodes	76.1	80.5	88.4

- 1 If equipped with hand-vent valve add 25 mm (1 in).
- 2 If equipped with float-lifting lever add 35 mm (1.4 in).

Equipment with flange ASME CL 300

	Type of cover	DN 40 (1½")	DN 50 (2")	DN 65 (2½")
L [mm (in)]	all	241 (9.5)	267 (10.5)	292 (11.5)
B [mm (in)]	Standard cover	328 (12.9)		
	Cover for mounting electrodes	343 (13.5)		
H1 [mm (in)]	all	98 (3.9)		
H2 [mm (in)]	all	182 (7.2) ¹		
H [mm (in)]	all	280 (11.0) ¹		
L1 [mm (in)]	all	160 (6.3) ²		
X [mm (in)]	all	13 (0.5)		
Weight [kg]	Standard cover	34.8	36.2	39.9
	Cover for mounting electrodes	36.7	38.1	41.7
Weight [lb]	Standard cover	76.7	79.8	88.0
	Cover for mounting electrodes	80.9	84.0	91.9

- 1 If equipped with hand-vent valve add 25 mm (1 in).
- 2 If equipped with float-lifting lever add 35 mm (1.4 in).

Equipment with socket-weld ends

	Type of cover	DN 40 (1½")	DN 50 (2")	DN 65 (2½")
L [mm (in)]	all	165 (6.5)	267 (10.5)	292 (11.5)
B [mm (in)]	Standard cover	328 (12.9)		
	Sightglass cover	370 (14.6)		
	Cover for mounting electrodes	343 (13.5)		
H1 [mm (in)]	all	98 (3.9)		
H2 [mm (in)]	all	182 (7.2) ¹		
H [mm (in)]	all	280 (11.0) ¹		
L1 [mm (in)]	all	160 (6.3) ²		
X [mm (in)]	all	13 (0.5)		
Weight [kg]	Standard cover	29.9	30.9	32.2
	Sightglass cover	33.8	34.8	36.1
	Cover for mounting electrodes	31.7	32.8	34.1
Weight [lb]	Standard cover	65.9	68.1	71.0
	Sightglass cover	74.5	76.7	79.6
	Cover for mounting electrodes	69.9	72.3	75.2

- 1 If equipped with hand-vent valve add 25 mm (1 in).
- 2 If equipped with float-lifting lever add 35 mm (1.4 in).

Equipment with screwed socket

	Type of cover	DN 40 (1½")	DN 50 (2")
L [mm (in)]	all	165 (6.5)	
B [mm (in)]	Standard cover	328 (12.9)	
	Sightglass cover	370 (14.6)	
	Cover for mounting electrodes	343 (13.5)	
H1 [mm (in)]	all	98 (3.9)	
H2 [mm (in)]	all	182 (7.2) ¹	
H [mm (in)]	all	280 (11.0) ¹	
L1 [mm (in)]	all	160 (6.3) ²	
X [mm (in)]	all	13 (0.5)	
Weight [kg]	Standard cover	30.1	29.6
	Sightglass cover	34.0	33.5
	Cover for mounting electrodes	32.0	31.4
Weight [lb]	Standard cover	66.4	65.3
	Sightglass cover	75.0	73.9
	Cover for mounting electrodes	70.5	69.2

- 1 If equipped with hand-vent valve add 25 mm (1 in).
- 2 If equipped with float-lifting lever add 35 mm (1.4 in).

Equipment with butt-weld end via transition pieces

	Type of cover	DN 40 (1½")	DN 50 (2")	DN 65 (2½")
L [mm (in)]	all	241 (9.5)	267 (10.5)	292 (11.5)
B [mm (in)]	Standard cover	328 (12.9)		
	Sightglass cover	370 (14.6)		
	Cover for mounting electrodes	343 (13.5)		
H1 [mm (in)]	all	98 (3.9)		
H2 [mm (in)]	all	182 (7.2) ¹		
H [mm (in)]	all	280 (11.0) ¹		
L1 [mm (in)]	all	160 (6.3) ²		
X [mm (in)]	all	13 (0.5)		
Weight [kg]	Standard cover	30.1	30.4	31.3
	Sightglass cover	34.0	34.3	35.2
	Cover for mounting electrodes	32.0	32.3	33.2
Weight [lb]	Standard cover	66.4	67.0	69.0
	Sightglass cover	75.0	75.6	77.6
	Cover for mounting electrodes	70.5	71.2	73.2

- 1 If equipped with hand-vent valve add 25 mm (1 in).
- 2 If equipped with float-lifting lever add 35 mm (1.4 in).

Space required for servicing

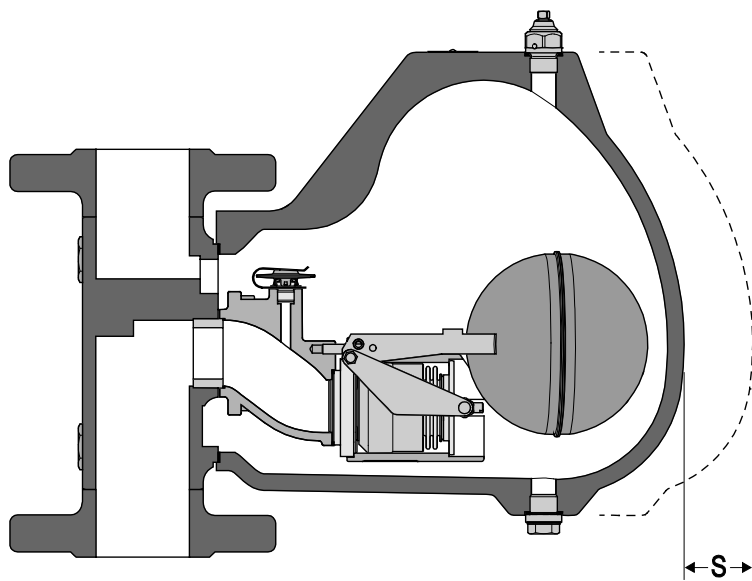

To remove the cover a withdrawal space S of 270 mm is required.

If the supplied socket spanner is attached to the equipment an additional clearance of 100 mm is required.

Pressure & temperature ratings

The values indicated in the following tables apply to standard equipment.

Note that the type of end connection used may restrict the use of the equipment to below the pressure/temperature limits quoted.

All equipment specific values are indicated on the nameplate.

Limiting conditions for UNA 45 MAX with sightglass cover, flange PN 16, screwed sockets G						
Pressure ¹ p	[barg]	16.0	14.8	14.0	13.3	12.3
Temperature ¹ T	[°C]	-10/20	100	150	200	240
Max. admissible differential pressure ΔPMX	[barg]	4, 8, 13, (16 bar with orifice 22, 32)				
	[psi]	58, 116, 188, (230 psi with orifice 22, 32)				
Admissible service temperature	Control unit DUPLEX: Saturated steam temperature plus 5 K					
Pressure ¹ p	[psig]	232	215	203	193	178
Temperature ¹ T	[°F]	14/68	212	302	392	464

1 Resistance limits for body/cover to EN 1092-1

Limiting conditions for UNA 45 MAX with sightglass cover, flange Class 150, screwed sockets NPT, socket-weld end, butt-weld end						
Pressure ¹ p	[barg]	19.6	17.7	15.8	13.8	12.4
Temperature ¹ T	[°C]	-29/20	100	150	200	240
Max. admissible differential pressure ΔPMX	[barg]	4, 8, 13, (19,6 bar with orifice 22, 32)				
	[psi]	58, 116, 188, (284 psi with orifice 22, 32)				
Admissible service temperature	Control unit DUPLEX: Saturated steam temperature plus 5 K					
Pressure ¹ p	[psig]	285	260	230	200	180
Temperature ¹ T	[°F]	-20/100	200	300	400	465

1 Resistance limits for body/cover to ASME B 16.5

Limiting conditions for UNA 45 MAX and UNA 46 MAX: Flange PN 40, screwed sockets G							
Pressure ¹ p	[barg]	40	37.1	33.3	27.6	25.7	13.1 ²
Temperature ¹ T	[°C]	-10/20	100	200	300	350	450 ²
Max. admissible differential pressure ΔPMX	[barg]	4, 8, 13, 22, 32					
	[psi]	58, 116, 188, 320, 465					
Admissible service temperature	Control unit DUPLEX: Saturated steam temperature plus 5 K						
Pressure ¹ p	[psig]	580	538	483	400	373	190 ²
Temperature ¹ T	[°F]	14/68	212	392	572	662	842 ²

- 1 Resistance limits for body/cover to EN 1092-1
- 2 Not for UNA 45 MAX

Limiting conditions for UNA 45 MAX and UNA 46 MAX: Flange Class 150							
Pressure ¹ p	[barg]	19.6	17.7	13.8	10.2	8.6	5.5 ²
Temperature ¹ T	[°C]	-29/20	100	200	300	345	425 ²
Max. admissible differential pressure ΔPMX	[barg]	4, 8, 13, (19,6 bar with orifice 22, 32)					
	[psi]	58, 116, 188, (284 psi with orifice 22, 32)					
Admissible service temperature	Control unit DUPLEX: Saturated steam temperature plus 5 K						
Pressure ¹ p	[psig]	285	260	200	140	125	80 ²
Temperature ¹ T	[°F]	-20/ 100	200	400	600	650	800 ²

- 1 Resistance limits for body/cover to ASME B 16.5
- 2 Not for UNA 45 MAX

Limiting conditions for UNA 45 MAX and UNA 46 MAX: Flange Class 300, screwed sockets NPT, socket-weld end, butt-weld end							
Pressure ¹ p	[barg]	51.1	46.6	43.8	39.8	37.8	28.8 ²
Temperature ¹ T	[°C]	-29/20	100	200	300	345	425 ²
Max. admissible differential pressure ΔPMX	[barg]	4, 8, 13, 22, 32					
	[psi]	58, 116, 188, 320, 465					
Admissible service temperature	Control unit DUPLEX: Saturated steam temperature plus 5 K						
Pressure ¹ p	[psig]	740	680	635	570	550	410 ²
Temperature ¹ T	[°F]	-20/ 100	200	400	600	650	800 ²

- 1 Resistance limits for body/cover to ASME B 16.5
- 2 Not for UNA 45 MAX

Limiting conditions for UNA 46A MAX, flange PN 40, screwed sockets G							
Pressure ¹ p	[barg]	40.0	37.9	31.8	27.6	25.7	25
Temperature ¹ T	[°C]	-10/20	100	200	300	400 ²	450 ²
Max. admissible differential pressure ΔPMX	[barg]	4, 8, 13, 22, 32					
	[psi]	58, 116, 188, 320, 465					
Admissible service temperature	Control unit DUPLEX: Saturated steam temperature plus 5 K						
Pressure ¹ p	[psig]	580	550	461	400	373	363
Temperature ¹ T	[°F]	14/68	212	392	572	752	842

- 1 Resistance limits for body/cover to EN 1092-1
- 2 If the operating temperatures exceed 300 °C intercrystalline corrosion may occur. Do not subject the equipment to operating temperatures higher than 300 °C unless intercrystalline corrosion can be ruled out.

Limiting conditions for UNA 46A MAX, flange Class 150							
Pressure ¹ p	[barg]	15.9	13.3	11.2	10.0	6.5	5.5
Temperature ¹ T	[°C]	-29/20	100	200	300	400 ²	425 ²
Max. admissible differential pressure ΔPMX	[barg]	4, 8, 13, (15,9 bar with orifice 22, 32)					
	[psi]	58, 116, 188, (230 psi with orifice 22, 32)					
Admissible service temperature	Control unit DUPLEX: Saturated steam temperature plus 5 K						
Pressure ¹ p	[psig]	230	195	160	140	95	80
Temperature ¹ T	[°F]	-20/100	200	400	600	750	800

- 1 Resistance limits for body/cover to ASME B 16.5
- 2 If the operating temperatures exceed 300 °C intercrystalline corrosion may occur. Do not subject the equipment to operating temperatures higher than 300 °C unless intercrystalline corrosion can be ruled out.

Limiting conditions for UNA 46A MAX, flange Class 300, screwed socket NPT, socket-weld end, butt-weld end							
Pressure ¹ p	[barg]	41.4	34.8	29.2	26.1	24.3	23.9
Temperature ¹ T	[°C]	-29/20	100	200	300	400 ²	425 ²
Max. admissible differential pressure ΔPMX	[barg]	4, 8, 13, 22, 32					
	[psi]	58, 116, 188, 320, 465					
Admissible service temperature	Control unit DUPLEX: Saturated steam temperature plus 5 K						
Pressure ¹ p	[psig]	600	510	420	370	355	345
Temperature ¹ T	[°F]	-20/100	200	400	600	750	800

- 1 Resistance limits for body/cover to ASME B 16.5
- 2 If the operating temperatures exceed 300 °C intercrystalline corrosion may occur. Do not subject the equipment to operating temperatures higher than 300 °C unless intercrystalline corrosion can be ruled out.

Operating data

Equipment with sightglass cover:

PN16: max. service temperature 240 °C at

12.3 bar service pressure

Class 150: max. service temperature 240 °C at

12.4 bar service pressure.

If the pH value is above 9.0 and the fluid temperature exceeds 200 °C the glass will wear down faster.

Equipment with measuring electrode NRG 16–19 or

NRG 16–27, PN40/Class300:

max. service temperature 238 °C at 32 bar service

pressure

Equipment with control unit DUPLEX: max. service

temperature corresponds to the saturation

temperature +5 K.

The max. differential pressure Δ PMX of the equipment depends on the type of orifice (O) used.

MAX Orifice	ΔPMX [bar]	Diameter of bore [mm]
4	4	27.5
8	8	19.4
13	13	15.3
22	22	11.7
32	32	9.7

Manufacturer's declaration

For more information on the Conformity Assessment according to European rules refer to our Declaration of Conformity or our Declaration by Manufacturer.

To download the current Declaration of Conformity or Declaration by Manufacturer go to www.gestra.com/documents or contact:

GESTRA AG

Münchener Straße 77

28215 Bremen

Germany

Telefon +49 421 3503-0

Telefax +49 421 3503-393

E-Mail info@de.gestra.com

Web www.gestra.de

This declaration is no longer valid if modifications are made to the equipment without consultation with us.



Agencies all over the world: www.gestra.de

GESTRA AG

Münchener Straße 77

28215 Bremen

Germany

Telefon +49 421 3503-0

Telefax +49 421 3503-393

E-Mail info@de.gestra.com

Web www.gestra.de

819401-02/07-2016 kx_mp (808916-02) © GESTRA AG Bremen Printed in Germany